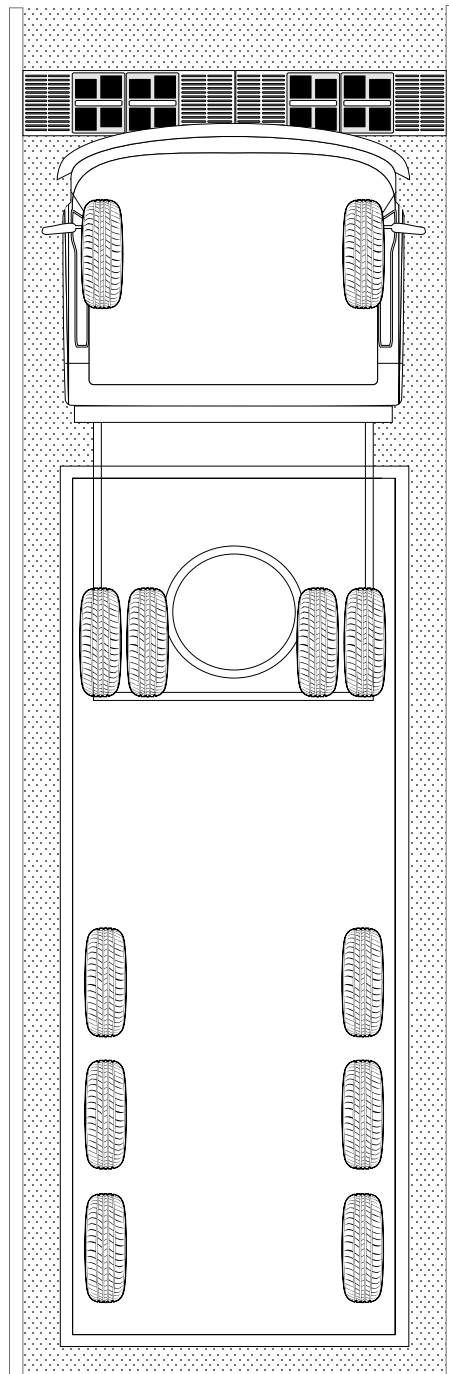
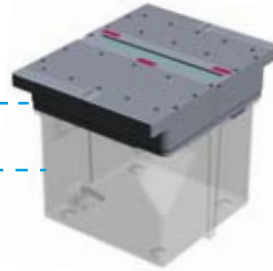

DIAGRAM OF PASSENGER CAR/LORRY CHECK



Schematic drive-over situation of a five-axle articulated lorry.



The sensor heads are installed in an underground channel. For tyre depth measurement ProContour recommends a total of four modules (two left and two right of the centre of the vehicle).

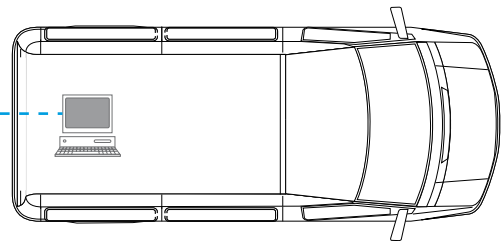

The measurement data are transferred via a data cable to a PC station.



Simple and ergonomically optimised operation of the system is intuitive using a graphical user interface.



All tyres recorded are visualised on the graphical user interface during the measuring process. If the tread depth falls below the minimum tread depth configured in the system, the measured image is stored in the history where it can be viewed/printed at any time.